

CBUCK Engineering

Specialty Structural Engineering

CBUCK, Inc. Certificate of Authorization #8064

Evaluation Report "HR-16" Panel Metal Wall Assembly

Manufacturer:
Berridge Manufacturing Company

**1720 Maury Road
Houston, TX 77026
(800) 231-8127**

for

Florida Product Approval

FL 17437.2 R4

Florida Building Code 8th Edition (2023)

Method: 2 - B

Category: Structural Components

Sub - Category: Structural Wall

Product: "HR-16" Wall Panel

Material: 0.032" Aluminum or 24 ga. Steel

Prepared by:

James L. Buckner, P.E., S.E.C.B.
Florida Professional Engineer # 31242
Florida Evaluation ANE ID: 1916
Project Manager: Diana Galloway
Report No. 23-542-HR46-ASG-ER
(Revises Report No. 20-227-HR46-ASG-ER, FL17437.2 R3)
Date: 09/26/2023

Contents:

Evaluation Report Pages 1 – 7

This item has been digitally signed and sealed by James L. Buckner, P.E., on this date below. Printed copies of this document are not considered signed and sealed, and the signature must be verified on any electronic copies.

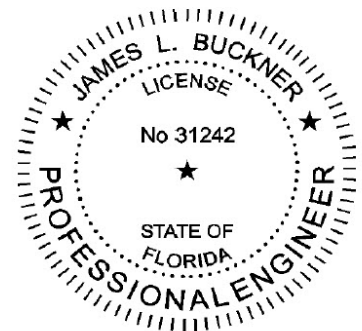

James L. Buckner, P.E.
FL31242

Date: 2023.09.26 15:25:27
-04'00

CBUCK, Inc. dba CBUCK Engineering

Phone: (561) 491-9927 · Email: cbuck@cbuckinc.net · Website: www.cbuckinc.net
Business: 1374 Community Dr., Jupiter, FL 33458

Manufacturer:	Berridge Manufacturing Company 1720 Maury Road Houston, TX 77026 (800) 231-8127 www.berridge.com
Product Name:	"HR-16" Panel
Product Category:	Structural Components
Product Sub-Category	Structural Wall
Compliance Method:	State Product Approval Rule 61G20.005 (2) (b)
Product/System Description:	"HR-16" Panel Structural wall panels with concealed fasteners, a flush seam and interlocking seam edge. Panels are attached to steel supports with screws.
Product Assembly as Evaluated:	Refer to Page 4 of this report for product assembly components/materials & standards: <ol style="list-style-type: none">1. Wall Panel2. Fasteners3. Bearing Plate
Support:	Steel Supports (Design of steel support and its attachment to support framing is outside the scope of this evaluation.) Description: Material: Steel Thickness: 16 Gauge minimum Yield Strength: 40 ksi minimum Girt/Stud Size: 2" min. flange bearing
Performance:	Wind Uplift Resistance: <ul style="list-style-type: none">• Design Uplift Pressure: Refer to Table "A" (Refer to "Table A" attachment details herein)
Performance Standards:	The product described herein has demonstrated compliance with: <ul style="list-style-type: none">• ASTM E 1592-05 (2017) – <i>Test Method for Structural Performance of Sheet Metal Wall/soffit and siding Systems By Uniform Static Air Pressure Difference</i>• ASTM E 330-14 – <i>Test Method for Structural Performance of Exterior Windows, Curtain Walls and Doors by Uniform Static Air Pressure.</i>

Standards Equivalency: The TAS 202-94 standard version used to test the evaluated product assembly is equivalent with the prescribed standards in ASTM E330-14 as adopted by the Florida Building Code 8th Edition (2023).
The ASTM E 1592-01 standard version used to test the evaluated product assembly is equivalent with the prescribed standards in ASTM E 1592-05 (2015) adopted by the Florida Building Code 8th Edition (2023).

Code Compliance: The product described herein has demonstrated compliance with Florida Building Code 8th Edition (2023), Section 1708.2.

Evaluation Report Scope: This product evaluation is limited to compliance with the structural requirements of the Florida Building Code, as related to the scope section to Florida Product Approval Rule 61G20.001.

Limitations and Conditions of Use:

- Diaphragm and axial load capacity is outside the scope of this evaluation.
- Scope of "Limitations and Conditions of Use" for this evaluation:
This evaluation report for "Optional Statewide Approval" contains technical documentation, specifications and installation method(s) which include "Limitations and Conditions of Use" throughout the report in accordance with Rule 61G20-3.005. Per Rule 61G20-3.004, the Florida Building Commission is the authority to approve products under "Optional Statewide Approval".
- Option for application outside "Limitations and Conditions of Use"
Rule 61G20-3.005(1)(e) allows engineering analysis for "project specific approval by the local authorities having jurisdiction in accordance with the alternate methods and materials authorized in the Code". Any modification of the product as evaluated in this report and approved by the Florida Building Commission is outside the scope of this evaluation and will be the responsibility of others.
- This report is a building code product evaluation per FLPE rule (FAC) 61G15-36 to comply with Florida product approval rule (FAC) 61G20-3. This evaluation report is part of the Florida Building Commission approval for the listed code related criteria. This report by James Buckner, P.E. and CBUG Engineering is not a design certification of code compliance construction submittal documentation, per FBC section 107, for any individual structure, site specific or permit design.
- All metal components and fasteners shall be corrosion resistant in accordance with applicable sections of FBC.
- Design of support system is outside the scope of this report. Support shall be designed by others and shall comply with the FBC Chapters 22 for steel and Chapter 16 for structural loading.
- Fire Classification is outside the scope of Rule 61G20-3, and is therefore not included in this evaluation.

Quality Assurance: The manufacturer has demonstrated compliance of products in accordance with the Florida Building Code and Rule 61G20.0005 (3) for manufacturing under a quality assurance program audited by an approved quality assurance entity through UL, LLC (FBC Organization #: QUA 9625)

**Components/Materials
(by Manufacturer):**

Wall Panel:
Panel Width: Berridge "HR-16" Panel
Rib Height: 16" Coverage
Material: 7/8"
Aluminum OR Steel
Thickness: Aluminum: 0.032" Steel: 24 gauge
Alum. Alloy Type: 3105-H14, in compliance with ASTM B 209
Steel Yield Strength: 50 ksi min.
Steel Grade: 40
Corrosion Resistance: In compliance with FBC Section 1405.2

Fasteners:

Option #1:

Type: Low Profile Head Self-Drilling Screw
Size : **#12 - 14 x 3/4"**
Material: Galvanized Steel or Stainless Steel
Corrosion Resistance: Per FBC Section 1405.17
Standard: Per SAE J78-1979

Option #2:

Type: Low Profile Head Self-Drilling Screw
Size : **1/4" - 14 x 1"**
Material: Aluminum-Zinc or Stainless Steel
Corrosion Resistance: Per FBC Section 1405.17
Standard: Per SAE J78-1979

Option #3:

Type: Hex-Washer-Head Self-Drilling Screw
Size : **#12 - 14 x 1-1/4" with 5/8" washer head**
Material: Aluminum-Zinc or Stainless Steel
Corrosion Resistance: Per FBC Section 1405.17
Standard: Per SAE J78-1979

Bearing Plate:

Dimensions: 1-3/8" x 4-1/2" x 1-1/4"
With Aluminum Panel:
Material: Aluminum or Stainless Steel
Thickness: 0.032" Alum or 24 gauge Steel
With Steel Panel:
Material: Galvanized or Stainless Steel
Thickness: 24 gauge

Installation:

Installation Method:

(Refer to "TABLE A" and drawings at the end of this report.)

Install per the following:

- Support spacing: Per Table "A"
- Fastener spacing: Per Table "A"
- Two (2) fasteners per max. support (girt/stud) and panel lap intersections
- Fasteners shall be centered in the flange of each attachment point.
- Panel ribs shall be fully engaged to form an integral interlock.
- Minimum fastener penetration thru flange of steel support: 3/4".
- Wall Panels are to be installed vertically or horizontally.

Install the "HR-16" wall panel assembly in compliance with the installation method listed in this report and applicable code sections of FBC 8th Edition (2023). The installation method described herein is in accordance with the scope of this evaluation report. Refer to manufacturer's installation instructions as a supplemental guide for attachment.

TABLE "A" "HR-16" 0.032" Aluminum or 24 ga. Steel Wall Panel" "HR-16" ALLOWABLE LOADS									
#	Material/ Thickness	Fastener (Per Pg 4)	Support Type	Support Spacing (max.)	Fastener Spacing (exposure)	# Fasteners Per Attachment	Bearing Plate (Y/N)	Span Condition	Design Pressure (PSF)
1.	24 ga. Steel	Option 1 (#12)	Steel Girts	24" (2'- 0")	16"	2	N	3 or more	+ 65 - 115
2.	0.032" Alum	Option 2 (1/4")	Steel Girts	24" (2'- 0")	16"	2	N	3 or more	- 78
3.	0.032" Alum	Option 3 (#12)	Steel Girts	24" (2'- 0")	16"	2	Y	3 or more	- 41.63
NOTES: <ul style="list-style-type: none"> • Negative Pressure Outward/Positive Pressure Inward • Allowable design pressure(s) for allowable stress design (ASD). • Fastener Attachment to Steel Supports May Be Designed By A Qualified Design Professional As Required By The Florida Building Code For Site Specific Projects. • Diaphragm and axial load capacity are not included in this evaluation 									

Referenced Data:

1. TAS 201-94, 202-94, 203-94
By Architectural Testing, Inc., Southlake, TX
Report No.: 78918-02-801-18, Dated: 8/20/09.
Signed & Sealed 8/24/09 by Joseph A. Reed, P.E.
2. TAS 125-03 Uplift Test (per ASTM E 1592-01)
By Force Engineering & Testing Inc., Inc. (FBC Organization #TST ID:5328)
Report # 49-0022T-14C,G, Report Date: 3/6/14
3. Quality Assurance
UL, LLC (FBC Organization #: QUA 9625)
4. Test Equivalency Statement
By James L. Buckner, P.E. @ CBUCK Engineering
5. Certification of Independence
By James L. Buckner, P.E. @ CBUCK Engineering
(FBC Organization # ANE 1916)

Installation Method
Berridge Manufacturing Company
"HR-16" 0.032" Aluminum or 24 ga. Steel Wall Panel"

Profile Drawings

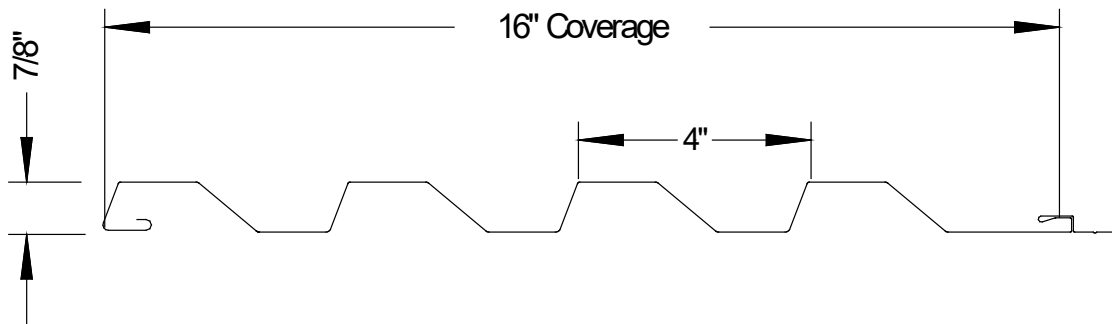

**Typical "HR-16" Panel
Profile View**

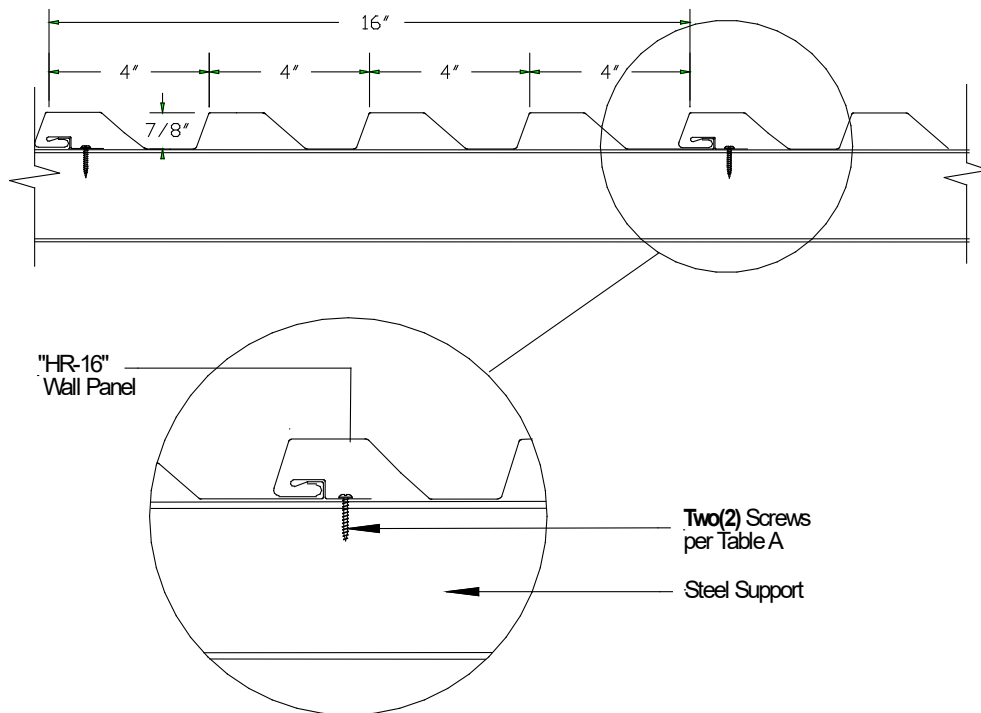

**"HR-16" Panel Assembly
Typical Section View**

Installation Method Berridge Manufacturing Company "HR-16" 0.032" Aluminum or 24 ga. Steel Wall Panel

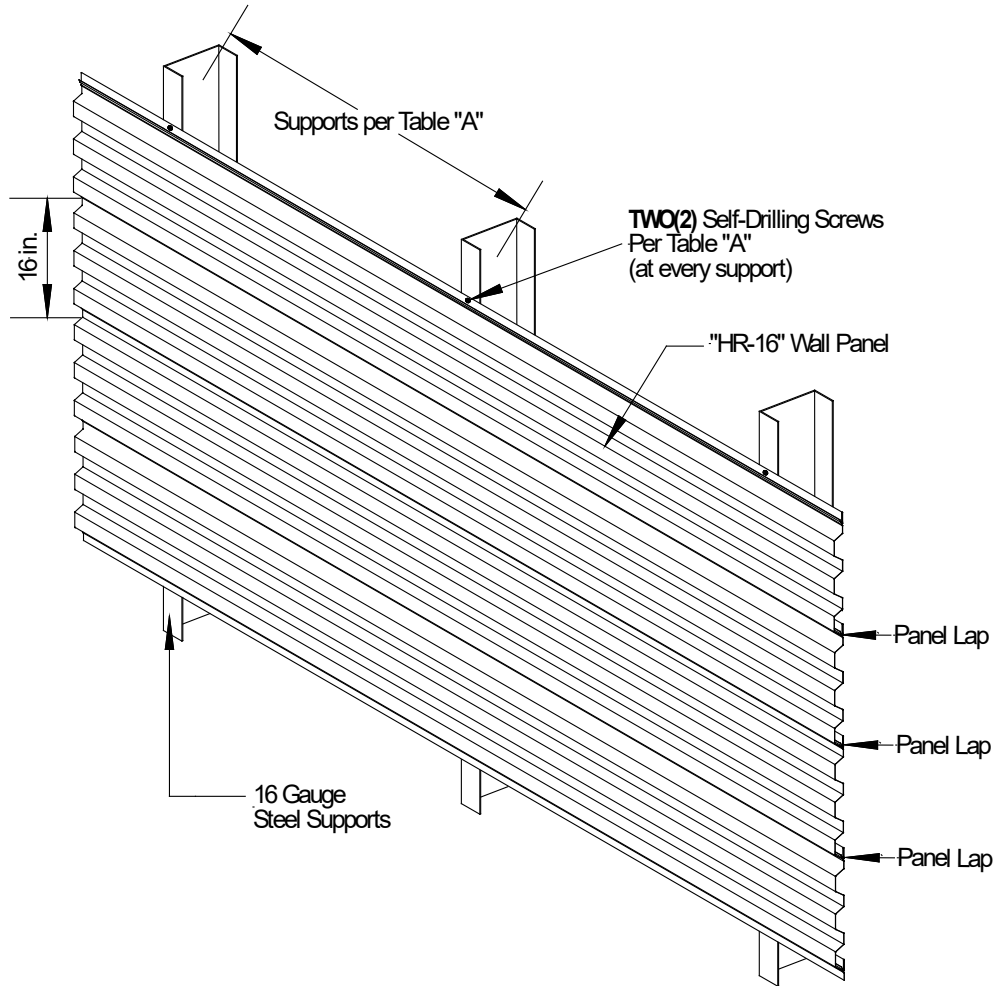

**Typical Elevation View
 Outside Of Wall Assembly**

TABLE "A"									
ALLOWABLE LOADS									
#	Material/ Thickness	Fastener (Per Pg 4)	Support Type	Support Spacing (max.)	Fastener Spacing (exposure)	# Fasteners Per Attachment	Bearing Plate (Y/N)	Span Condition	Design Pressure (PSF)
1.	24 ga. Steel	Option 1 (#12)	Steel Girts	24" (2'- 0")	16"	2	N	3 or more	+ 65 - 115
2.	0.032" Alum	Option 2 (1/4")	Steel Girts	24" (2'- 0")	16"	2	N	3 or more	- 78
3.	0.032" Alum	Option 3 (#12)	Steel Girts	24" (2'- 0")	16"	2	Y	3 or more	- 41.63